

DO NOT REMOVE!

Except By Owner/User

IMPORTANT SAFETY AND OPERATIONS INFORMATION INSIDE



VKX2-3(R,SC,B)
VKX2-3(R,B)-15

VELKE X2 PACKING LIST:

VELKEX2:

2WHEELASSEMBLIES
FOOTPLATEWITH 2 SPANNERS, 2WASHERS,2 L1NCHPINS
18"ARM FORVKX2-3(R,SC,B)WITH INTERMEDIATE PIVOT
(15"ARM FORVKX2-3(R,B)-15 WITH INTERMEDIATEPIVOT)
HITCH
ADAPTERPLATE
TWO 3/8" x 1 1/4" BOLTS, LOCKNUTS

REMAINING HARDWARE IN KIT:

BAG
SNAP
CHAIN
TWO 3/8" x 1" BOLTS, LOCKNUTS
ONE 5/16" x 1" BOLT
ONE5/16"LOCKNUT

LITERATUREBAG

BAG

THIS DOUBLE-SIDED 3 PAGE PACKAGE:

- DO NOTREMOVEWARNING/PACKING LIST
- PARTS LISTWITH DIAGRAM
- SAFETYWARNINGS
- INSTALLATION INSTRUCTIONS

LUBRICATION WARNING

C84BEST "Four best workers..," FLYER

WARRANTY



4600X Wedgewood Blvd., Frederick, Maryland, 21703 U.S.A.

ph. 301.360.9810 fax.301.360.9820



U.S. PATENT # 5,004,251 (Pro 1 & X2)
5,810,371; 5,882,020; 6,000,705; 6,234,495 & Pats. Pend.
Made in U.S.A.

INSTALLATION & ASSEMBLY INSTRUCTIONS

NOTE: The velke sulky must be installed correctly for best performance. Follow carefully starting at STEP 1.

STEP 2

In most cases the handlebars will need to be raised as high as they will go for comfort. If your mower's handlebars are supported by threaded rods, use the extra length to raise them higher. Many mowers have hidden holes for the adjustment of the top section of the handlebars. Use the highest setting. You may need to readjust the control linkages of the mower after changing handlebar height.

STEP 4

Transport chain: (note: changing handlebar position after setting chain length prevents proper operation.) Attach the chain somewhere centered to the mower and when possible toward the rear of the dash panel. See the examples shown below. If you need to drill, be careful not to damage hidden parts.(5/16" hole) Attach the hook so that the Velke hangs up as high as possible using the more compact method with just enough slack for unhooking it. Cut off excess chain.

STEP 3

The preferred method for folding the X2 up under the handlebars is shown at right. This method is used to lock the Velke in a more compact position to prevent it from swinging wildly.

TO FOLD COMPACTLY:

Lift the platform and rotate it on its rearmost pivot until the left wheel reaches the 2 o'clock position (see arrow 1). Next rotate the platform on the middle pivot (see arrow 2) until the v-notch engages with the arm. Now rotate the X2 up the rest of the way (arrow 3).

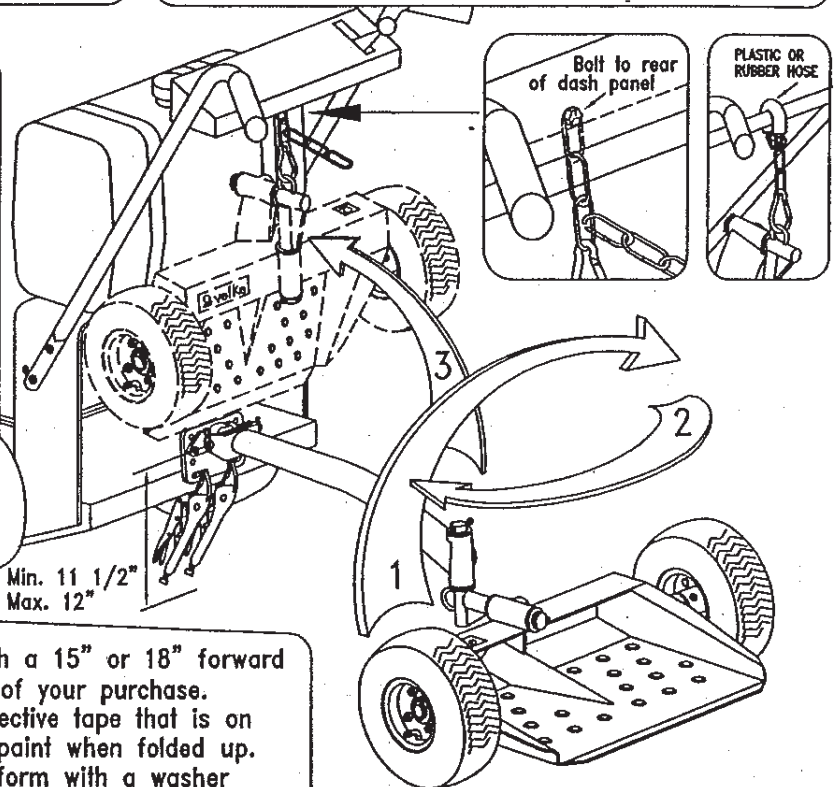

STEP 1

Some Velke models are available with a 15" or 18" forward arm. See reverse if you are unsure of your purchase. Do not remove the polyurethane protective tape that is on the forward arm. It will protect the paint when folded up. Attach the arm assembly to the platform with a washer against each bronze bushing and install the cotter pin. Bend both ends of both cotter pins. Install each wheel with the washer under the linch pin. Attach the hitch (and adapter plate if needed) to the rear face of the mower (never on top face) with the center of the hitch pin at 11 1/2 inches from the ground using existing bolt holes or vise grips if you need to drill holes. Hitch can be turned over giving more increments for height. See "MORE HELP" on reverse for unusual applications. If you need to drill holes, make sure you don't damage parts behind drilling surface. Mark with center punch, drill 3/8" holes. Face bolts out when needed to avoid contact with pulleys, belts, etc. Tighten all bolts. Attach the Velke to the hitch with the hitch pin always installed from the right. This allows the pin to turn on the bushings only.

STEP 5

- GREASE ALL 5 FITTINGS BEFORE USING, AND DAILY THEREAFTER. WARNING: THE WHEEL BEARINGS WILL BE DESTROYED IN MINUTES IF USED DRY. (no grease when shipped)
- MIN/MAX TIRE PSI IS 20 TO 30 (can change platform height and give a smoother or stiffer ride)
- READ THE SAFETY INSTRUCTIONS NOW AND REQUIRE EVERY USER TO READ IT BEFORE USING. "ENJOY"



4600X Wedgewood Blvd., Frederick, Maryland, 21703 U.S.A. • 301.360.9810 • fax.301.360.9820



U.S. PATENT # 5,004,251 (Pro 1 & X2)
 # 5,810,371; 5,882,020; 6,000,705; 6,234,495 & Pats. Pend.
 Made in U.S.A.

MORE HELP

(Use in addition to the instruction sheet)

The Velke will work on most any walk-behind mower if attached correctly. You may have to do a little more work than usual if your mower is like one of these shown.

Note: Correct hitch height must be obtained for the Velke to work correctly. See "HITCH HEIGHT" below.

Please write any comments about the Velke on your Warranty Registration form.

TRANSMISSION OVERHANGS BUMPER

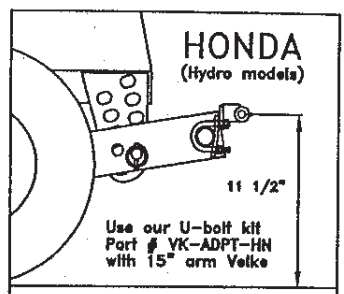
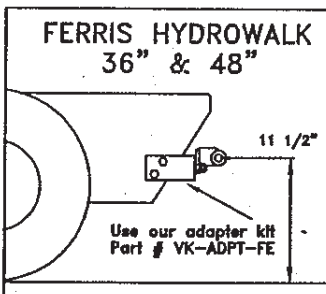
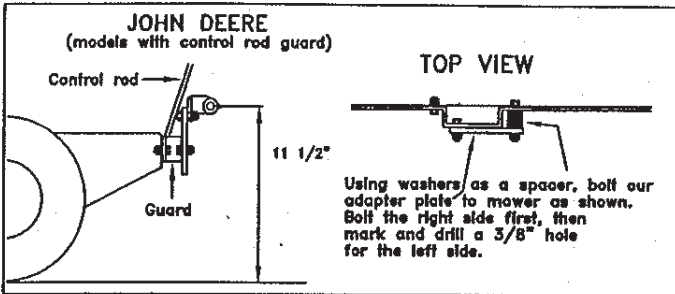
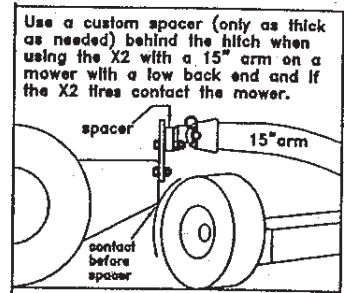
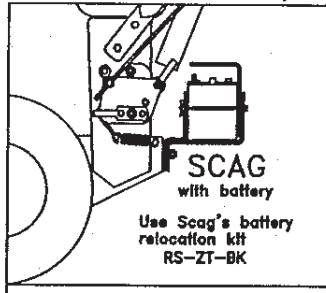
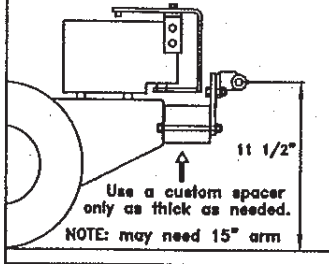

THE ARM QUESTIONS

Q: What arm is recommended for my mower?

A: Some mower Makes are known to nearly always take the same Velke arm no matter what model or year the walkbehind is.

Example: All Scags take the 18"
 All Toros take the 15"
 All Gravelys take a 15"

Rarely does anyone prefer the other size arm for those mowers.

Some mower Makes often take a particular size arm based on the model, year, or type (hydro, gear drive, loop handle, pistol grip, etc.) Also if custom spacers are needed behind the hitch in order to fold the Velke up and to obtain the correct hitch height. Your equipment dealer can often give you the best advice as to which arm is usually preferred for your mower.

Many times a mower could use either size arm equally well and would be chosen by personal preference. Keep in mind that the handlebar position if changed can make a difference in your choice (highest handlebar setting is recommended in most cases).

Q: What do I do if I install the Velke to try it and decide that the other size arm would be better?

A: First ask your dealer what they will do for an exchange. You may exchange the arm with us for a new arm of the other size if it is clean, unscratched, unused and in saleable condition. Slightly used or scratched arms can be exchanged for equal (or slightly lesser) quality if it is available. Call first!

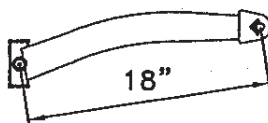

Q: Why would I use the 18" arm?

A: The 18" arm may be desired if the 15" arm causes you to get jabbed by the handlebars as you turn or if the X2 wheels come in contact with the back end of the mower while it turns for backing. You may only need to space the hitch out 1/2" or more to use the 15" arm on mowers with the lower back end as low as 7 inches from the ground (See above).

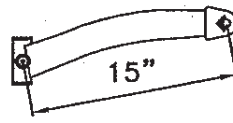
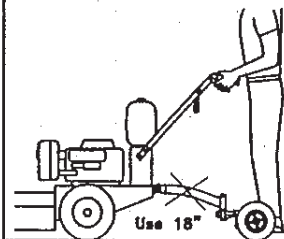

Q: Why would I use the 15" arm?

A: The 15" arm may be desired if the 18" arm causes you to lean forward to reach the handlebars as with the mower shown below.

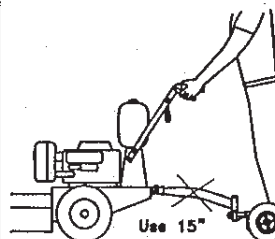

HITCH HEIGHT

The hitch height determines the angle of the foot platform and the reaction it has when it rotates to 180 degrees for a quicker and more maneuverable reverse.

If the hitch is mounted too high, the Velke is likely to be run over by the mower when backing up over uneven ground.

If the hitch is mounted too low, the rear of the platform will hit the ground and may act as a plow when going forward again.

The recommended height from the hitch pin to the ground for all mowers is 11 1/2 inches.

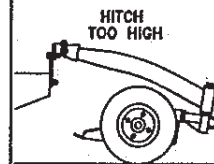

11 1/2" to hitch pin recommended.

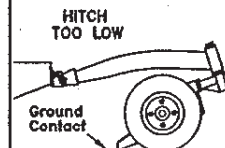
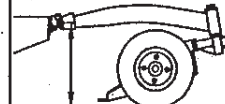

4600X Wedgewood Blvd., Frederick, Maryland, 21703 U.S.A. • 301.360.9810 • fax.301.360.9820

Velke™ Sulky: PRO1 & X2 Parts List



Pro1 REF#	X2 REF#	PART#	Color Code: R=red, SC=orange, B=black DESCRIPTION
1		VK200-2 (R,SC,B)	VELKE SULKY, PRO 1 w/18" square tube arm [specify R,SC,B]
1		VK200-2 (R,B)-15	VELKE SULKY, PRO 1 w/15" square tube arm [specify R,B]
1		VK200-2WV	VELKE SULKY,PRO 1 for Wright Velke Mower [adpt.& chain kit n/inc.]
	1X	VKX2-3 (R,SC,B)	VELKE SULKY, X2 w/18" square tube arm [specify R,SC,B]
	1X	VKX2-3 (R,B)-15	VELKE SULKY, X2 w/15" square tube arm [specify R,B]
	1X	VKX2-3WV	VELKE SULKY,X2 for Wright Velke Mower [adpt.& chain kit n/inc.]
2		VKWHEEL	Wheel Assy., w/ centered hub & spanner 9x3.50-4
	2X	VKXWHEEL	Wheel Assy., w/ offset hub & spanner 9x3.50-4
	2X	72310001(VKXWHEEL 11")	Wheel Assy., w/ offset hub & spanner 4.10x3.50-4
2a		VKTIRE	9x3.50-4 Ply Turf Tread Tire
	2Xa	72320001(VKXTIRE 11")	4.10x3.50-4 Ply Turf Tread Tire
2b		VKTUBE	9x3.50 Tube for VKTIRE
	2Xb	72320002 (VKXTUBE 11")	4.10x3.50 Tube for 11" VKXTIRE
2c		VKRIM/HUB	4" x 2.25" 3 Piece Rim/Centered Hub Assy. (w/o bearings)
	2Xc	VKXRIM/HUB	4" x 2.25" 3 Piece Rim/Offset Hub Assy. (w/o bearings) 9" & 11" tire
2d		VKBRGKIT	Bearing Kit PRO 1 (w/Roller Bearing, Retainers & Spanner)
	2Xd	VKXBRGKIT	Bearing Kit X2 (w/Roller Bearing, Retainers & Spanner)
2e		VKSPNNR	Spanner, 3/4" O.D.
	2Xe	VKXSPNNR	Spanner, 1" O.D.
2f		VKRLBRG	Roller Bearing, 3/4" I.D.
	2Xf	VKXRLBRG	Roller Bearing, 1" I.D.
2g		VKBRGRTNR	Bearing Retainer, 3/4" I.D. (2 required)
	2Xg	VKXBRGRTNR	Bearing Retainer, 1" I.D. (2 required)
2h		VKWLZERK	Grease Fitting For VKWHEEL & VKXWHEEL
3		VKPLAT2-2 (R,SC,B,WV)	Foot Platform PRO 1 (w/decals) [specify R,SC,B,WV]
	3X	VKXPLAT2-2 (R,SC,B,WV)	Foot Platform X2 (w/decals, bushings, zerk) [specify R,SC,B,WV]
4		VKAXLE2-2	Axle Bolt (w/spacers and self locking nut)
	4X	VKXLPIN	Linch Pin for X2 axle
5		VKARM2-2(R,SC,B)	Arm, 18" square tube (w/ bushings & grease fitting) [specify R,SC,B]
5		VKARM2-2WV	Arm, 18" square tube (w/ bushings & grease fitting) for Wright Velke Mower with deployment latch
6		VPIVOTBUSH	Bronze Bushing pivot(s) (PRO1 req. 2; X2 req. 4)
7		VHITCBUSH	Bronze Bushing for hitch (2 required)
8		VKHITCH2-2-BLK	Hitch (w/ bushings & grease fitting) [Black]
9		VELKIT2-2	Snap & Chain Kit (includes chain, snap, nut, bolt)
9a		VSNAP	Spring Snap for chain
10		VKPIN2-2	Clevis pin for hitch, w/ hair pin & roll pins
11		VADAPTER	Adapter plate for hitch height adjustment
12		VK-ADPT-FE	14.25" Adapter to mount VELKE to Ferris Hydro Walk
		VK-ADPT-FE16	16.375" Adapter to mount VELKE to Ferris Walkbehinds
		VK-ADPT-FE29	29.25" Adapter to mount VELKE to Ferris Walkbehinds
13		VK-ADPT-HN	U-Bolt kit for attaching VELKE to Honda Hydro
not shown		VK-ADPT-JD	For John Deere Hydro Walkbehinds w/hydro tank in frame (must use 15" arm)
14		VKARM-SHORT (R,B)	Optional SHORT 15" square tube arm (w/bushings) [specify R,B]
15		VKLABEL	Decal set for VELKE PRO 1 Sulky (incl. all three)
	15X	X2-VKLABEL	Decal set for VELKE X2 Sulky (incl. 2 labels)
16		VKSPCKIT	Spacer kit (includes both sizes needed, 4 total)
	16X	VKXSPCKIT	Spacer kit (includes both sizes needed, 6 total)
	17X	VKXPIVPIV-BLK	Intermediate Pivot (Black Only)
	18X	VKXPROTEC	Protective cover (for fold-up feature)
19		15990010	E Clip 7/8": (PRO 1 req. 1; X2 req. 2) (Supercedes Cotter Pin)
20		76490060	Decal, Sulky Reverse Warning
x	x	CB4BEST	4-Color Sales Flyer, "Four best workers..."
x	x		COMMON: Other common hardware should be purchased locally. All bolts must be grade 5.

Wright Manufacturing Inc. 4600X Wedgewood Blvd., Frederick, Maryland, 21703 U.S.A. – phone 301-360-9810 - fax 301-360-9820

© 1991-2010 Wright Manufacturing, Inc. All Rights Reserved Velke, Velke Pro1, Velke X2 are trademarks of Wright Manufacturing Inc.

PRO 1 and X2 Options

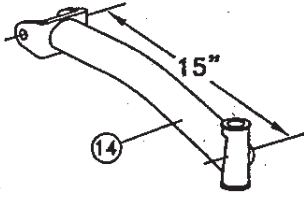
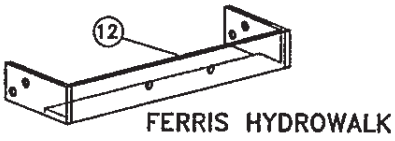

Common Parts for velke PRO 1 and X2

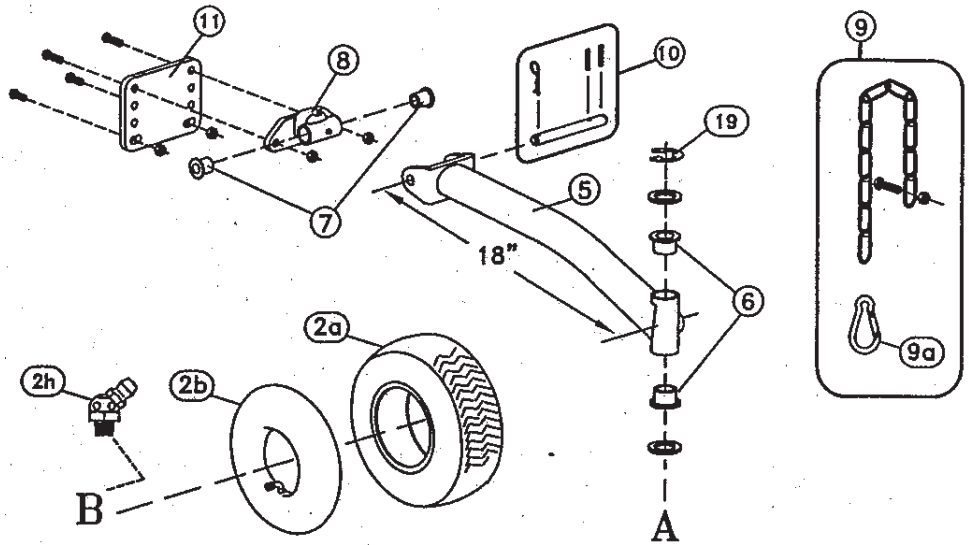

Parts for velke X2 only

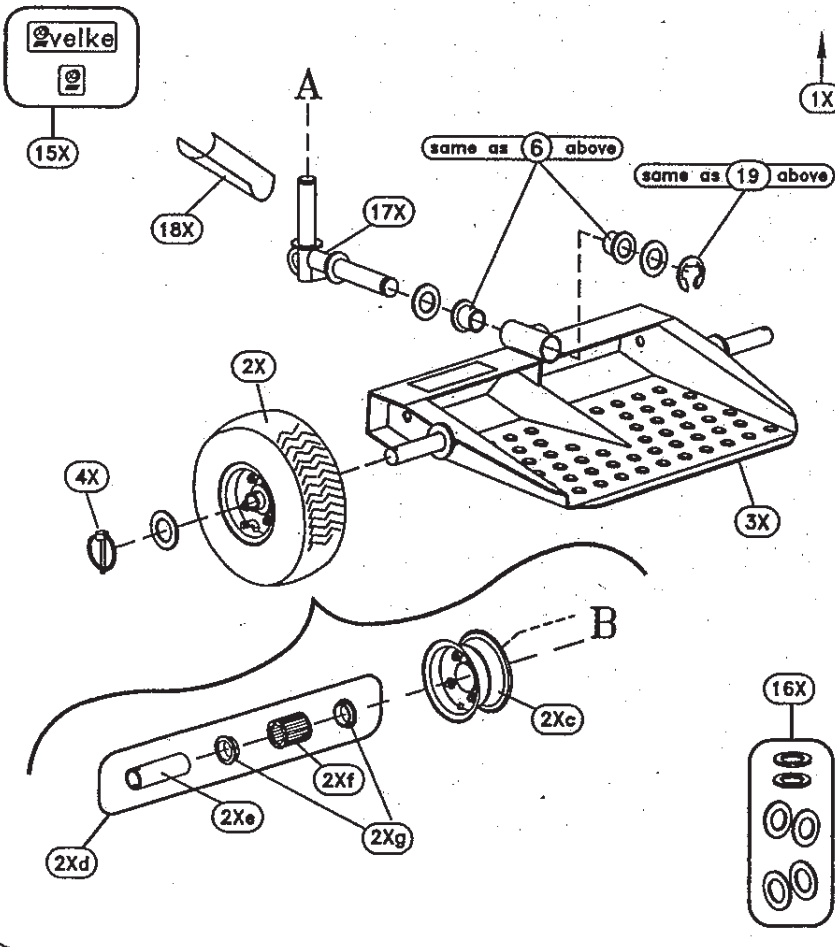

Parts for velke PRO 1 only

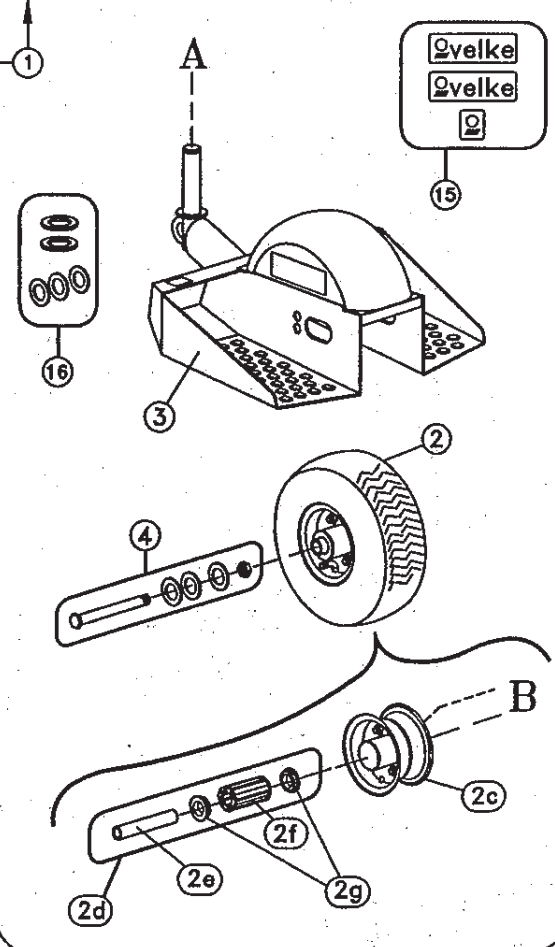

WARNING!!
READ THIS BEFORE USING



WARNING!!
READ THIS BEFORE USING

VELKE SAFETY WARNINGS

- 1. Do not use the Velke Sulky until you are completely familiar with the operation of the particular mower that it is attached to. We recommend at least one month experience walking behind the mower before riding.**
- 2. Make sure all safety equipment provided with the mower is in operating order. This includes operator presence devices that will shut the mower off in case you let go of the handles.**
- 3. Wear thick-soled, high-top leather work boots. No bare feet!**
- 4. Do not attempt to operate the mower in reverse gear while standing on the Velke sulky.**
- 5. Operate the mower at slower speeds until you become familiar with how the Velke sulky handles. It won't be long before it becomes natural. Some users compare it to skiing.**
- 6. Do not operate the mower faster than you could walk comfortably. Speeding is dangerous even when trotting (or running) behind a mower. Sudden stops from excessive speed may cause serious injury. The Velke will make you more efficient by just maintaining a healthy pace through the day without speeding.**
- 7. Never use any mower near and by-standers in case you lose control or objects are thrown from the mower.**
- 8. Do not allow inexperienced people to use the Velke until they have read and understand this sheet, and have significant experience walking behind a commercial/industrial mower.**
- 9. Do not use the Velke sulky if any parts become loose. Examine the moving parts each time you use it. Look for loose or missing bolts, cotter or hair pins and replace immediately.**



4600X Wedgewood Blvd.,
Frederick, Maryland, 21703
U.S.A.
ph. 301.360.9810
fax.301.360.9820

Wright Manufacturing, Inc., the manufacturer of the Velke sulky, thanks you for purchasing this new product. We're working to help you make money. Please write or call us if you would like to receive product update information or if you have any questions about its use or installation. We're here to give you 100% satisfaction. Our local Velke dealers are authorized to service and sell our product in your area. Please give them your support.