

# DM-1-4 BULL RIDER "caster wheel" Sulky

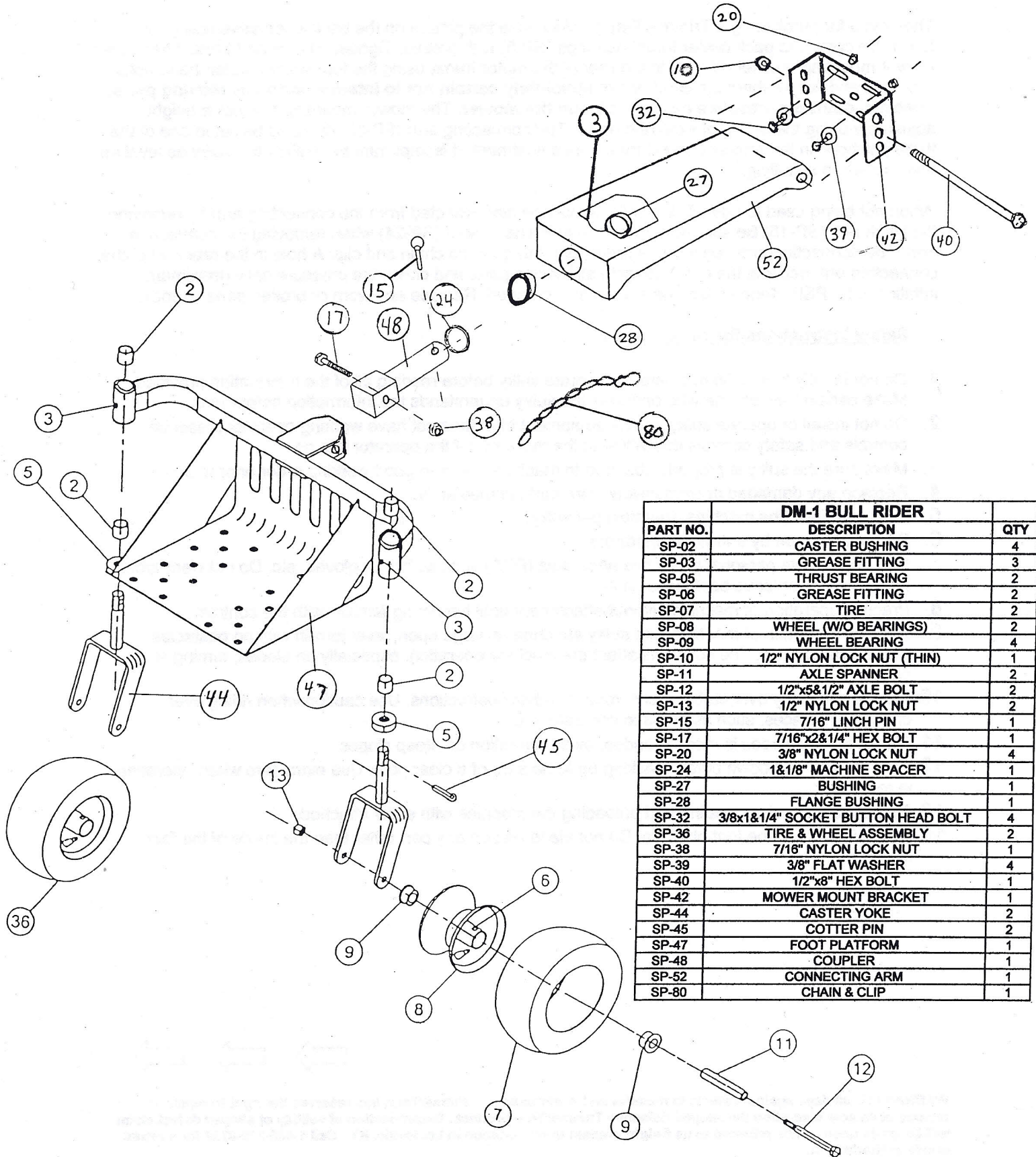

DM-1 BULL RIDER		
PART NO.	DESCRIPTION	QTY
SP-02	CASTER BUSHING	4
SP-03	GREASE FITTING	3
SP-05	THRUST BEARING	2
SP-06	GREASE FITTING	2
SP-07	TIRE	2
SP-08	WHEEL (W/O BEARINGS)	2
SP-09	WHEEL BEARING	4
SP-10	1/2" NYLON LOCK NUT (THIN)	1
SP-11	AXLE SPANNER	2
SP-12	1/2"x5&1/2" AXLE BOLT	2
SP-13	1/2" NYLON LOCK NUT	2
SP-15	7/16" LINCH PIN	1
SP-17	7/16"x2&1/4" HEX BOLT	1
SP-20	3/8" NYLON LOCK NUT	4
SP-24	1&1/8" MACHINE SPACER	1
SP-27	BUSHING	1
SP-28	FLANGE BUSHING	1
SP-32	3/8x1&1/4" SOCKET BUTTON HEAD BOLT	4
SP-36	TIRE & WHEEL ASSEMBLY	2
SP-38	7/16" NYLON LOCK NUT	1
SP-39	3/8" FLAT WASHER	4
SP-40	1/2"x8" HEX BOLT	1
SP-42	MOWER MOUNT BRACKET	1
SP-44	CASTER YOKE	2
SP-45	COTTER PIN	2
SP-47	FOOT PLATFORM	1
SP-48	COUPLER	1
SP-52	CONNECTING ARM	1
SP-80	CHAIN & CLIP	1